

## WEP TEST

### Wasser-Eintritts-Prüfung

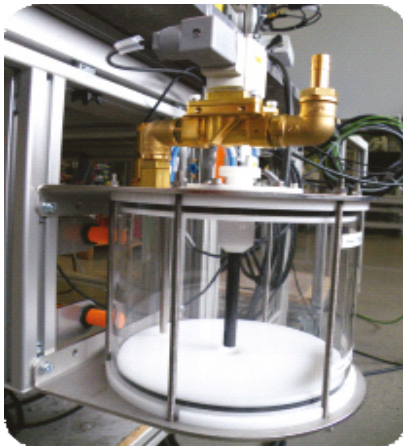
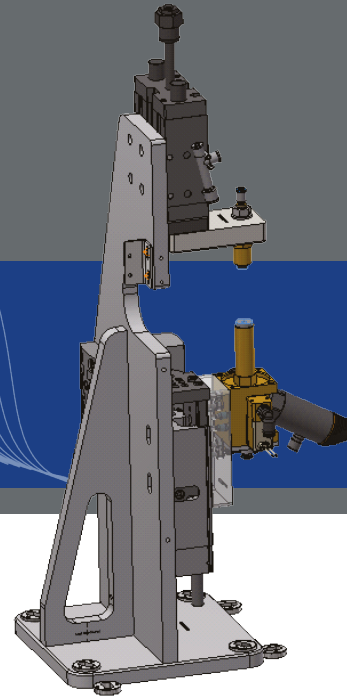

### PROZESSABLAUF

1. Abdichten Prüfteil
2. Einstellbarer Druckaufbau
3. Prüfung DAE-Membrane auf Wasserdurchbruch
4. Druckabbau
5. Freigabe Prüfteil

### VORTEILE

- o 100% Dichtheitsprüfung im Serienprozess
- o Prüfung innerhalb von 6s
- o DAE-Dichtheitsprüfung mit Wasser
- o Parametrierbar in: Prüfzeit, Prüfdruck, Anstieg Druckrampe
- o Selbsttestendes System



## WEP TEST

## Water-Leak-Test

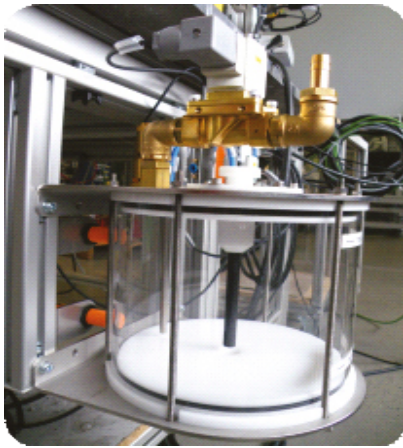
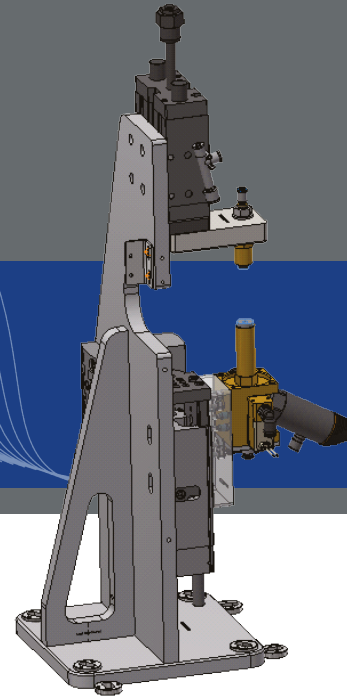

### PROCESS PROCEDURE

1. Sealing the test part
2. Adjustable pressure build up
3. ePTFE-membrane on water breakthrough
4. Pressure reduction
5. Release of the test part

### BENEFITS

- o 100% leak test in series process
- o Testing within 6s
- o ePTFE-membrane through test with water
- o Parameterizable in: test time, test pressure, pressure ramp
- o Self-testing system

